

---

## **The Influence of CAR, NPL, and LDR on Profitability in Private Banks in Indonesia which are Classified as Commercial Banks Business Activities 3 in The Period 2014-2018**

**Lisa J.C. Polimpung<sup>1)</sup>, Jie Lydia Irawan<sup>2)</sup>**

<sup>1,2)</sup> Master of Management at Parahyangan Catholic University

Jl. Merdeka No. 30, Bandung

Email: lisapolimpung0117@gmail.com<sup>1)</sup>, jielydiarawan@gmail.com<sup>2)</sup>

### **ABSTRACT**

Bank is a financial institution that has an important role in the economy. The bank's performance is important to know both by the bank itself and by investors where investors need to know the performance of a bank so that they can be sure of the security guarantees for the funds they invest in the bank. This study analyzes the effect of Capital Adequacy Ratio (CAR), Non Performing Loan (NPL), and Loan to Deposit Ratio (LDR) on Return On Assets (ROA). In this study using multiple linear regression using 10 banks which are included in Commercial Banks for Business Activities 3 and classified as private banks in the 2014-2018 period. The partial test results show that CAR and NPL have an effect on ROA, while LDR has no effect on ROA. Simultaneously, CAR, NPL, and LDR have an effect on ROA

**Keywords: CAR, NPL, LDR, ROA**

### **1. INTRODUCTION**

Bank is a financial institution which has the main task or activity, namely collecting funds from the public. According to Monica (2019), a bank is a financial institution where in addition to collecting funds from the public, banks also channel funds to the public and provide services in other banking sectors or are intermediaries between parties who have advantages or disadvantages in funds. Banking itself is a financial industry that has a function in collecting funds that are less productive in the community and channeling these funds to become credit in the business world.

Commercial Banks for Business Activities or in Indonesia called Bank Umum Kegiatan Usaha (BUKU) are divided into 4 groups, namely BUKU 1 which has the criteria of core capital of less than or up to Rp 1 trillion, BUKU 2 with the criteria of core capital of less than or up to Rp 5 trillion, BUKU 3 with the following criteria: core capital of at least Rp 5 trillion to Rp 30 trillion and BUKU 4 with core capital of at least Rp 30 trillion (Bank Indonesia Regulation Number 14 of 2012). Broadly speaking, when viewed through ownership status, banks can be divided into four categories, namely state-owned banks, national privately-owned banks, foreign-owned banks and joint venture banks.

In the banking sector, the risk of failure that occurs generally lies in the inability to handle the credit portfolio or errors in the company's management where this will cause difficulties that occur in financial conditions and business failures which in the long run will hamper the economy. nationally (Avrita and Pangestuti, 2016). However, this condition is a reciprocal condition where

if the national economy itself experiences instability or declines, the performance in the banking sector will also experience a slowdown.

It is important for the bank's performance to be known both by the bank itself and by investors. Investors need to know the performance of a bank so that they can be sure of the security guarantees for the funds they invest in the bank. The better the financial performance of a bank, it shows that the higher the security guarantee that the bank has (Monica, 2019). One way that can be used to assess bank performance is to use financial ratios which produce objective numbers.

Financial ratios allow investors to assess the company's financial performance in the present and in the past and can be a guide in assessing future performance (Nurunnisak, Dhiana and Putri 2018). This study uses the variables Capital Adequacy Ratio (CAR), Non Performing Loan (NPL), and Loan to Deposit Ratio (LDR) to profitability which is reflected by the ratio of Return on Assets (ROA) where in measuring profitability, the three variables are variables that commonly used (Agustiningrum, 2013 and Warsa and Mustanda, 2016).

CAR is a bank performance ratio that is used to calculate or measure the capital adequacy of a bank in supporting assets that have or create risk (Putri and Satrio, 2019). Research conducted by Harun (2016), Dewi (2017) and Purtri (2019) found that the CAR variable has no effect on ROA. The results of this study are different from the results of research conducted by Vernanda and Widarti (2016), Suciaty, Haming, and Alam (2019) and Sudarmawanti and Pramono (2017) which state that CAR has an influence on ROA.

NPL is a ratio used to show a bank's ability to manage credit to be disbursed, but it is substandard and doubtful and bad (Putri and Satrio, 2019). Research conducted by Dewi (2017), Avrita and Pangestuti, (2016) and Chandra and Anggraini (2020) shows that NPL has a different effect on ROA than research conducted by Harun (2016) and Putri and Satrio (2019), which found that NPL has no effect on ROA

According to Putri and Satrio (2019) LDR is used to measure a bank's ability to pay debts, repay depositors and be able to fulfill credit requests submitted by users. Research conducted by Dewi (2017) and Harun (2016) shows that LDR has an effect on ROA, while research conducted by Avrita and Pangestuti, (2016) and Putri and Satrio (2019), shows that LDR has no effect on ROA.

ROA is a probability ratio used to describe the level of efficiency of the company's management on profitability where profitability is a performance evaluation tool in company management. According to Siaman (2004) in Warsa and Mustanda (2016), ROA is an indicator used to measure financial performance and is a profitability ratio used to measure a company's effectiveness in generating profits. Avrita and Pangestuti (2016) explain that it is more important to use ROA assessment than other variables because in determining bank health, BI prioritizes profitability. The greater the ROA in a bank, the greater the bank's ability to manage its profit assets.

This study uses BUKU 3 banks where in Indonesia itself there was a tightening of liquidity carried out in May 2018 when BI increased the reference book rate level (CNBC Indonesia, 2019) and through data obtained at OJK it was found that among the 4 BUKU groupings, BUKU 3 experienced the tightest liquidity (Tobing, 2019) and this caused BUKU 3 to increase the special rate deposit interest rate which exceeded BUKU 1 and BUKU 2 (CNBC Indonesia, 2018). Ownership status, the bank used in this study is a national private bank, because the funds owned by private banks are their own funds and there is no outside influence.

Based on the explanation above, the research model in this study is as follows:

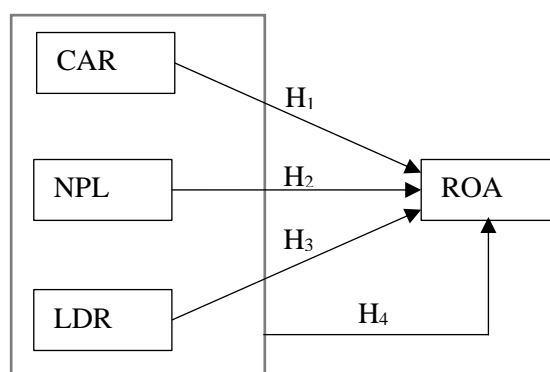

**Figure 1**  
**Hypothesis Model**

Based on Figure 1, it can be seen that the research hypothesis of the study can be described as follows:

H<sub>1</sub>: CAR affects ROA

H<sub>2</sub>: NPL affects ROA

H<sub>3</sub>: LDR affects ROA

H<sub>4</sub>: CAR, NPL and LDR have a simultaneous effect on ROA

## 2. THEORETICAL BASIS

### 2.1. Capital Adequacy Ratio (CAR)

CAR is a bank performance ratio that is used to measure the adequacy of capital owned by a bank in supporting assets that contain risks. Eng, 2013; Monica, 2019; and Putri and Satrio 2019). Harun (2016) explains that CAR briefly increases the confidence of banks when disbursing credit. Furthermore, Harun (2016) explains that the higher the CAR, the higher the financial resources that can be used to carry out business development purposes and to anticipate possible losses due to lending will also be higher. The higher the CAR ratio, the greater the bank's profit and vice versa, where the lower the CAR ratio, the smaller the profit earned by the bank (Sudarmawanti and Pramono, 2017). The CAR ranking classification table and the calculation formula used in calculating CAR are as follows:

**Table 1**  
**Rank Classification CAR**

Predicate	Composite Value	Predicate
1	$CAR \geq 12\%$	Very Healthy
2	$9\% \leq CAR \leq 12\%$	Healthy
3	$8\% \leq CAR \leq 9\%$	Healthy Enough
4	$6\% \leq CAR \leq 8\%$	Unwell
5	$CAR \leq 6\%$	Not Healthy

Source: Codification of Bank Indonesia Regulations, 2012

$$CAR = \frac{\text{Bank Capital}}{\text{Risk Weighted Assets}} \times 100\%$$

## 2.2. Non Performing Loan (NPL)

According to Darmawan (2004) in Warsa and Mustanda (2016) NPL is a ratio used to measure a bank's ability to bear the risk of credit failure by debtors. Putri and Satrio (2019) explain NPL as a ratio that shows the ability of banks to manage loans that are disbursed, but are substandard, doubtful and bad. NPL is a key indicator used in evaluating the performance of bank functions (Monica, 2019). According to Harun (2016), the higher the NPL ratio, the worse the quality of bank credit, which causes the number of non-performing loans to increase so that the possibility of a bank in a problematic condition is greater. Tracey (2010) in Warsa and Mustanda (2016) briefly explains that a high NPL level will make the risk of experiencing losses in lending even higher. Sudarmawanti and Pramono (2017) explain that the higher the NPL ratio, the lower the bank's profitability. The ranking classification table and the NPL calculation formula are as follows:

**Table 2**  
**Rank Classification NPL**

Rank	Composite Value	Level
1	$NPL \leq 2\%$	Very Healthy
2	$2\% \leq NPL < 5\%$	Healthy
3	$5\% \leq NPL < 8\%$	Quite Healthy
4	$8\% \leq NPL < 12\%$	Less Healthy
5	$NPL \geq 12\%$	Not Healthy

Source: Bank Indonesia, 2012

$$NPL = \frac{\text{Bad Credit}}{\text{Total Credit}} \times 100\%$$

## 2.3. Loan to Deposit Ratio (LDR)

LDR is how much bank funds are released into credit (Lukitasari and Kartika, 2015). LDR is a measure of a bank's ability to repay withdrawals made by depositors and can fulfill credit requests submitted by users by relying on credit provided as a source of liquidity (Dendawijaya, 2005; Warsa and Mustanda, 2016; Putri and Satrio 2019). According to Harun (2016) LDR is a ratio used to describe the comparison between credit issued by a bank and the total third party funds collected by a bank. The higher the LDR of a bank will cause the bank to have difficulty in liquidity (Harun, 2016) so that the possibility of a bank being in a problematic condition is even greater. If the LDR ratio is at the healthy standard applied by BI, this indicates that the profitability of a bank will also increase (Pratiwi and Waigustini, 2015). Based on the table showing the standard classification of LDR set by BI, it can be seen that the lower the LDR, the higher the profitability of the bank, and vice versa.

**Table 3**  
**LDR Level**

Rank	Composite Value	Level
1	$LDR \leq 75\%$	Very Healthy
2	$75\% < LDR \leq 85\%$	Healthy
3	$85\% < LDR \leq 100\%$	Quite Healthy
4	$100\% < LDR \leq 120\%$	Less Healthy
5	$LDR > 120\%$	Not Healthy

Source: Bank Indonesia No. 6/23/DPNP/2004

The LDR calculation formula is as follows:

$$LDR = \frac{\text{Total Credit}}{\text{Total Third Party Funds}} \times 100\%$$

#### 2.4. Return On Asset (ROA)

ROA is a probability ratio used to describe the level of efficiency of the company's management on profitability where profitability is a performance evaluation tool in company management. ROA is the ratio of net income to total assets to measure the return on total assets after interest and taxes (Brigham and Houston, 2001 in Apriliani and Hartini, 2016). According to Siaman (2004) in Warsa and Mustanda (2016), ROA is an indicator used to measure financial performance and is a profitability ratio used to measure a company's effectiveness in generating profits. According to Christiano, Tommy, and Saerang (2014), ROA is the ratio between profit before tax to total assets. The greater the ROA owned by a bank, the greater the profit obtained and the better the bank's ability to manage assets for profit. The Rank Classification Table and the ROA calculation formula can be seen as follows:

**Table 4**  
**Rank Classification ROA**

Rank	Composite Value	Level
1	$ROA > 1,5\%$	Very Healthy
2	$1,25\% < ROA \leq 1,5\%$	Healthy
3	$0,5\% < ROA \leq 1,25\%$	Quite Healthy
4	$0\% < ROA \leq 0,5\%$	Less Healthy
5	$ROA \leq 0\%$	Not Healthy

Source: Bank Indonesia, 2012

$$ROA = \frac{\text{Net Profit}}{\text{Total Assets}} \times 100\%$$

### 3. RESEARCH METHODS

#### 3.1. Data Collection Technique

The data collection technique used in this research is secondary data. Secondary data is data that has been previously collected and then the data is used for purposes other than the objectives carried out in the research (Sekaran, 2016). Secondary data in this study is the bank's financial statements obtained in the Indonesia Stock Exchange (IDX).

### 3.2. Population and Sample

The population in this study are banking companies that fall into the BUKU 3 category, operating in Indonesia and whose financial reports are published on the Indonesia Stock Exchange. The sampling method is purposive sampling which uses the following criteria:

- The bank is included in the BUKU 3 bank category and is listed on the Indonesia Stock Exchange
- Banks that have complete and audited financial reports from 2014-2018
- Privately owned bank

Through the above criteria, it is found that there are 10 companies that meet the criteria.

### 3.3. Data Analysis Technique

#### 3.3.1. Multiple Linear Regression Analysis

According to Sekaran (2016), multiple regression analysis is a tool used to objectively assess the relationship between independent and dependent variables. This opinion is supported by Ghazali (2016) who explains that multiple regression analysis is used to show the relationship between variables independent and dependent variables.

#### 3.3.2. Hypothesis Test

To test the hypothesis in this study, the SPSS 22 program was used to obtain accurate data which analyzed the t test which was used to partially test the variables and the F test to test the variables simultaneously or simultaneously. The significant rate used in this study is 5%. If the significant value is  $> 0.05$ , it indicates that the hypothesis is rejected or the independent variable has no effect on the dependent variable either partially or simultaneously. If the significant value is  $< 0.05$  then this indicates that the hypothesis is accepted or the independent variable has an effect on the dependent variable partially or simultaneously.

## 4. RESULT AND DISCUSSION

### 4.1. Descriptive Statistic

Based on the results of data processing obtained statistical data as follows:

**Table 5**

	Descriptive Statistic		
	Min	Max	Mean
CAR	0.0912	0.3217	0.187136
NPL	0.0001	0.032	0.012364
LDR	0.5536	1.4067	0.91622
ROA	-0.0522	0.0339	0.0145

**Source: Processed data**

From the results of the descriptive statistical test, it was found that the average CAR of BUKU 3 banks was 19% with the highest figure of 32% and the lowest figure of 9% which showed that the bank's ability to fulfill the required minimum capital was in a very healthy category so that the bank's performance was included in the category very healthy. The NPL owned by BUKU 3 banks is an average of 1% and the highest value is 3% which shows that the credit risk owned by the bank is still in the safe category because based on the provisions of Bank Indonesia, NPL which is smaller than 5% is included in the category of NPL. - healthy gori. The

average LDR value obtained is 92% with the highest value of 141%, which means that there are still banks that are not good at managing the funds collected and loans provided so that the bank's LDR is in the category of quite healthy and unhealthy. ROA has the lowest value of -5.22% which means that the ability of banks in asset management to generate profits is still very lacking, because based on the provisions of Bank Indonesia's assessment, the ROA value obtained is categorized as unhealthy.

#### 4.2. Normality Test

The normality test in this study used the Kolmogorov-Smirnov test (KS test). KS test is used to determine whether the data distribution is normally distributed or not. The provisions used in the test are if the KS value  $> 0.05$  then the data is normally distributed, otherwise if the KS value is  $< 0.05$  then the data is not normally distributed.

**Table 6**  
**Normality Test**

Unstandardized Residual	
Asymp. Sig. (2-tailed)	0.184

**Source: Processed data**

Based on the results of the normality test using the KS test, it was found that the KS value  $> 0.05$ , which means that the data is normally distributed.

#### 4.3. Multicollinearities Test

In testing the correlation between the independent variables and the regression model, the multicollinearity test was used. This test uses the Variance Inflating Factor (VIF) and Tolerance test.

**Table 7**  
**Multicollinearities Test**

	Tolerance	VIF
CAR	0.176	5.68
NPL	0.853	1.172
LDR	0.727	1.376

**Source: Processed data**

Based on the provisions in decision making, if the Tolerance value  $> 0.10$  then there is no multicollinearity, on the contrary if the Tolerance value  $< 0.10$  then multicollinearity occurs in the regression model. If the value of VIF  $< 10.00$  then multicollinearity does not occur, otherwise if VIF  $> 10.00$  then multicollinearity occurs in the regression model. From the test results using SPSS, the Tolerance value  $> 0.10$  and the VIF value  $< 10.00$  then there is no multicollinearity in the regression model.

#### 4.4. Autocorrelation Test

Autocorrelation test is used to test the correlation between period  $t$  and the previous period ( $t-1$ ). A good regression model is a regression that is free from autocorrelation symptoms. For the autocorrelation test, the Durbin-Watson (dw) test equipment was used.

**Table 8****Autocorrelation Test**

<b>dU</b>	<b>dW</b>	<b>4-dU</b>
1.7214	2.050	2.2786

**Source: Processed data**

Based on the test results, obtained a dw value of 2.050 where based on the criteria  $dU < dW < (4-dU)$  the results obtained are  $1.7355 < 2.050 < 2.2645$ , so it can be concluded that there is no autocorrelation in the regression model.

**4.5. Heteroscedasticity Test**

This test aims to test whether there is a similarity of variance from the residuals of one observation to another observation. The test used is a test with the Glejser method, where the provisions in making decisions are used on the basis of if the value of Sig.  $> 0.05$  then there is no heteroscedasticity otherwise if the value of Sig.  $< 0.05$  means that there is heteroscedasticity in the regression model

**Table 9****Heteroscedasticity Test**

<b>Model</b>	<b>Sig.</b>
CAR	0.443
NPL	0.849
LDR	0.849

**Source: Processed data**

From the results of the heteroscedasticity test, it was found that the value of Sig.  $> 0.05$  means that there is no heteroscedasticity in the regression model.

**4.6. t Test**

This test is used to test the extent of the influence of the independent variable on the dependent variable partially. The significant level used in this test is 5%.

**Table 10****Uji t**

	<b>B</b>	<b>t</b>	<b>Sig.</b>
Constant	-5.819	-3.408	0.001
CAR	7.455	2.516	0.016
NPL	-32.333	-3.674	0.001
LDR	0.62	1.179	0.245

**Source: Processed data**

$$ROA = -5.819 + 7.455 \text{ CAR} - 32.333 \text{ NPL} + 0.62 \text{ LDR}$$

Based on the test results listed in the table above, it can be seen that the results obtained are as follows:

- A constant of -5,819 which means that if the independent variable is zero, the ROA will decrease by 5,819.
- CAR has a coefficient value of 7,455 which means that if the CAR increases by one unit, the ROA will increase by 7,455 units with the assumption that the other independent variables are constant. The significant value obtained is 0.016 where this value is smaller than the significant provisions used, namely 0.05, then the CAR has an effect on ROA.
- NPL has a coefficient value of -32,333 which means that if the NPL increases by one unit, the ROA will decrease by -32,333 units with the assumption that the other independent variables are constant. The significant value obtained from the test results of  $0.001 < 0.05$  means that NPL has an effect on ROA.
- LDR has a coefficient value of 0.62, which means that if the LDR increases by one unit, the ROA will increase by 0.62 units with the assumption that the other independent variables are constant. The significant value of LDR is  $0.245 > 0.05$ , which means that LDR has no effect on ROA.

#### 4.7. F Test

Based on the results of the F test at the table bellow, obtained a significant value of 0.037 where the value is smaller than the significant level of 0.05 so it can be concluded that the variables CAR, NPL, and LDR simultaneously affect ROA.

**Table 7**

**Uji F**

<b>Model</b>	<b>F</b>	<b>Sig.</b>
Regression	2.789	0.037

**Source: Processed data**

#### 4.8. Discussion

Based on the results of the t test, it was found that the CAR and NPL variables had an effect on ROA while the LDR variable had no effect on ROA. From the results of the F test, it is found that simultaneously the variables CAR, NPL, and LDR have an effect on ROA, this is in line with the proposed hypothesis.

The results of the partial test of the CAR variable, the results show that CAR has an effect on ROA, the results of this study support the proposed hypothesis. The influential CAR shows that the greater the CAR value, the better the management of capital owned by risk-weighted assets so that the profits obtained are also greater. The results of this study are in line with the research of Vernanda and Widyarti (2016), Suciati, Haming, and Alam (2019) and Sudarmawanti and Pramono (2017) which state that CAR has an influence on ROA.

From the results of the t test, obtained that NPL has an effect on ROA, the results of this study support the proposed hypothesis. The NPL that has an effect on ROA shows that the smaller the NPL, the better in credit management so that the profit obtained is also greater. The results of this study are in line with the research of Dewi (2017), Avrita and Pangestuti (2016) and Chandra and Angraini (2020).

The results of the t test for the LDR variable show that LDR has no effect on ROA, this result is not in accordance with or does not support the proposed hypothesis. LDR has no effect on ROA because LDR shows how the bank's ability to channel third party funds as credit to creditors, so that if the bank's LDR is too large, it means that the bank distributes all the funds received into credit and if there is a problem with the credit being disbursed, the bank will not pay. - have a reserve fund so that the profit obtained also becomes problematic or does not match the profit that

should be obtained. The results of this study are in line with the research of Avrista and Pangestuti (2016) and Putri and Satrio (2019).

## 5. CONCLUSION AND RECOMMENDATION

### 5.1. Conclusion

Based on the results and discussion, the conclusions that can be drawn are as follows:

- CAR affects ROA
- NPL affects ROA
- LDR has no effect on ROA
- CAR, NPL, and LDR have a simultaneous effect on ROA

The limitations in this study are that there are still some variables that are not included in the study and the objects used are still limited, not all banks.

### 5.2. Recommendation

The advice that can be given by researchers is that banks with poor performance should improve their performance which in addition to having an impact on investors and potential investors in the bank, this will also have an impact on the sustainability of the bank itself and the assessment of the bank in the public eye. To investors and potential investors, the advice that can be given is that before investing, investors and potential investors should research in advance about the performance of the bank to be invested so that they can reduce losses that can be obtained. For future research, suggestions that can be given are to enter other financial ratios or use different samples such as Islamic banks or banks in BUKU 1, 2 and 4 in seeing the effect on ROA.

## REFERENCES

- Agustiningrum, R. (2013). Analisis Pengaruh CAR, NPL dan LDR Terhadap Profitabilitas Pada Perusahaan Perbankan . *E-Jurnal Manajemen Unud Vol 2 No 8*, 885-902.
- Apriliani, F., & Hartini, E. F. (2016). Pengaruh Return on Asset dan Return on Equity Terhadap Return Saham Emiten LQ45. *Jurnal Pengembangan Wiraswasta Vol 18 No 3*, 199-208.
- Avrista, R. D., & Pangestuti, I. R. (2016). Analisis Pengaruh CAR, NPL, LDR, NIM dan BOPO Terhadap Profitabilitas Bank . *Diponegoro Journal of Management Vol 5 No 2*, 1-13.
- Chandra, S., & Anggraini, D. (2020). Pengaruh CAR, BOPO, LDR, NIM dan NPL Terhadap Profitabilitas Bank yang Terdaftar di BEI Tahun 2012-2018. *Bilancia: Jurnal Ilmiah Akuntansi Vol 4 No 3*, 298-309.
- Christiano, M., Tommy, P., & Saerang, I. (2014). Analisis Terhadap Rasio-Rasio Keuangan Untuk Mengukur Profitabilitas Pada Bank-Bank Swasta Yang Go Public di Bursa Efek Indonesia. *Jurnal EMBA Vol 2 No 4*, 817-830.
- CNBC Indonesia. (2018, October 20). Retrieved from <https://www.cnbcindonesia.com/market/20181030144755-17-39701/terungkap-bank-menengah-hadapi-pengetatan-likuiditas>
- CNBC Indonesia. (2019, July 20). Retrieved from <https://www.cnbcindonesia.com/market/20190719160719-17-86245/biakhirnya-pangkas-bunga-likuiditas-perbankan-apa-kabar>
- Dendawijaya, L. (2000). *Manajemen Perbankan*. Jakarta: Ghallia Indonesia.
- Dewi, A. S. (2017). Pengaruh CAR, BOPO, NPL, NIM dan LDR Terhadap ROA Pada Perusahaan di Sektor Perbankan yang Terdaftar di BEI Periode 2012-2016. *Jurnal Pundi Vol 1 No 3*, 223-236.

- Eng, S. T. (2013). Pengaruh NIM, BOPO, LDR, NPL dan CAR Terhadap ROA Bank Internasional dan Bank Nasional Go Public Periode 2007-2011. *Jurnal Dinamika Manajemen Vol 1 No 3*, 153-167.
- Ghozali, I. (2016). *Aplikasi Analisis Multivariate dengan Program IBM SPSS 23, Edisi 8*. Semarang: Universitas Diponegoro.
- Harun, U. (2016). Pengaruh Ratio-Ratio Keuangan CAR, LDR, NIM, BOPO, NPL Terhadap ROA. *Jurnal Riset Bisnis dan Manajemen Vol 4 No 1*, 67-82.
- idx.co.id*. (2020, April 3). Retrieved from *idx.co.id*: <https://www.idx.co.id/investor/pengantar-pasar-modal/>
- Kodifikasi Peraturan Bank Indonesia Kelembagaan Penilaian Tingkat Kesehatan Bank. (2012).
- Kuncoro, M., & Suhardjono. (2002). *Manajemen Perbankan : Teori dan Aplikasi*. Yogyakarta: BPFE.
- Lukitasari, Y. P., & Kartika, A. (2015). Analisis Pengaruh Dana Pihak Ketiga, BOPO, CAR, LDR dan NPL Terhadap Kinerja Keuangan Pada Sektor Perbankan yang Terdaftar di Bursa Efek Indonesia. *INFOKAM No 1*, 28-39.
- Monica. (2019). Analisis Pengaruh CAR, NPL, NIM, BOPO dan LDR Terhadap ROE Pada Bank Umum Swasta Nasional Devisa di Indonesia. *Jurnal Manajemen Bisnis dan Kewirausahaan Vol 3 No 3*, 8-17.
- Nurunnisak, I., Paramita, P. D., & Putri, M. A. (2018). Analisis Rasio Profitabilitas, Leverage, dan Likuiditas Terhadap Return Saham dengan Nilai Tukar Sebagai Variabel Moderating (Studi Empiris pada Perusahaan Manufaktur yang Terdaftar di LQ45 Periode 2013-2016). *Jurnal Ilmiah S1 Akuntansi Universitas Pandanaran Vol 4 No 4*.
- Pratiwi, L. S., & Wiagustini, N. P. (2015). Pengaruh CAR, BOPO, NPL dan LDR Terhadap Profitabilitas. *E-Jurnal Manajemen Unud Vol. 5 No. 4*, 2137-2166.
- Putri, A. S., & Satrio, B. (2019). Pengaruh CAR, NOP, BOPO, LDR dan NIM terhadap Profitabilitas Pada Perbankan. *Jurnal Ilmu dan Riset Manajemen Vol 8 No 7*.
- Sekaran, U., & Bougie, R. (2016). *Research Methods for Business 7th Edition*. United Kingdom: Wiley.
- Suciaty, A., Haming, M., & Alam, N. (2019). Pengaruh CAR, BOPO, NPL dan LDR Terhadap ROA Pada Bank BUMN Yang Terdaftar di Bursa Efek Indonesia. *Center of Economic Student Journal Vo 2 No 3*, 57-74.
- Sudarmawanti, E., & Pramono, J. (2017). Pengaruh CAR, NPL, BOPO, NIM dan LDR Terhadap ROA (Studi Kasus Pada Bank Perkreditan Rakyat di Salatiga yang Terdaftar di Otoritas Jasa Keuangan Tahun 2011-2015). *Among Makarti Vol.10 No.19*.
- Surat Edaran Bank Indonesia No. 6/23/DPNP/2004
- Tobing, S. (2019, Agustus 27). Diambil kembali dari *Katadata.co.id*: <https://katadata.co.id/telaah/2019/08/27/ancaman-likuiditas-perbankan-di-tengah-penurunan-suku-bunga-acuan>
- Vernanda, S. D., & Widyarti, E. T. (2016). Analisis Pengaruh CAR, LDR, NPL, BOPO dan Size Terhadap ROA. *Diponegoro Journal of Management Vol 5 No 3*, 1-13.
- Warsa, N. U., & Mustanda, I. K. (2016). Pengaruh CAR, LDR dan NPL Terhadap ROA Pada Sektor Perbankan di Bursa Efek di Indonesia. *E-Jurnal Manajemen Unud Vol 5 No 5*, 2842-2870.